

# Medium-Large Payloads Robot

# ER50-2100

**EFORT**

ER50-2100 is a medium payloads robot.  
Maxium payload 50 kg with maxium reach 2146 mm.

### Highlights

Thanks to the high stiffness structure, with high-speed intelligent palletizing application software, the takt is improved by 20%, bring customers more efficiency;  
Multiple specific application software could be integrated, with soft PLC and a variety of field bus interface, which enable customers easily face various application challenges;  
High performance collision detection function helps safety realization.

### Applications

It can be widely used in handling, polishing, palletizing, machine tending and other applications.

### Industries

Suitable for auto parts, photovoltaic, food and beverage, building materials, logistics and warehousing and other industries.



## SPECIFICATIONS

Model	ER50-2100	
Type	Articulated	
Controlled axes	6 Axes	
Max payload at wrist	50 kg	
Repeatability	± 0.06 mm	
Robot weight	550 kg	
Reach	2146 mm	
Robot IP grade	IP54/IP67 ( Wrist )	
Cabinet IP grade	IP54	
Drive mode	AC servo drive	
Installation	Floor	
Installation enviroment	Ambient temperature	0~45 °C
	Ambient humidity	80% RH/40°C(No dew nor frost allowed)
	Vibration acceleration	4.9 m/s <sup>2</sup> ( < 0.5 G )

Allowable load moment at wrist	J4	182 N · m
	J5	182 N · m
	J6	120 N · m
Allowable load inertia at wrist	J4	12.68 kg · m <sup>2</sup>
	J5	12.68 kg · m <sup>2</sup>
	J6	10 kg · m <sup>2</sup>
Maximum speed	J1	170°/sec
	J2	170°/sec
	J3	170°/sec
	J4	270°/sec
	J5	270°/sec
	J6	365°/sec
Motion range	J1	± 180°
	J2	+70°/- 130°
	J3	+175°/-80°
	J4	± 360°
	J5	± 115°
	J6	± 450°

## OPERATING SPACE

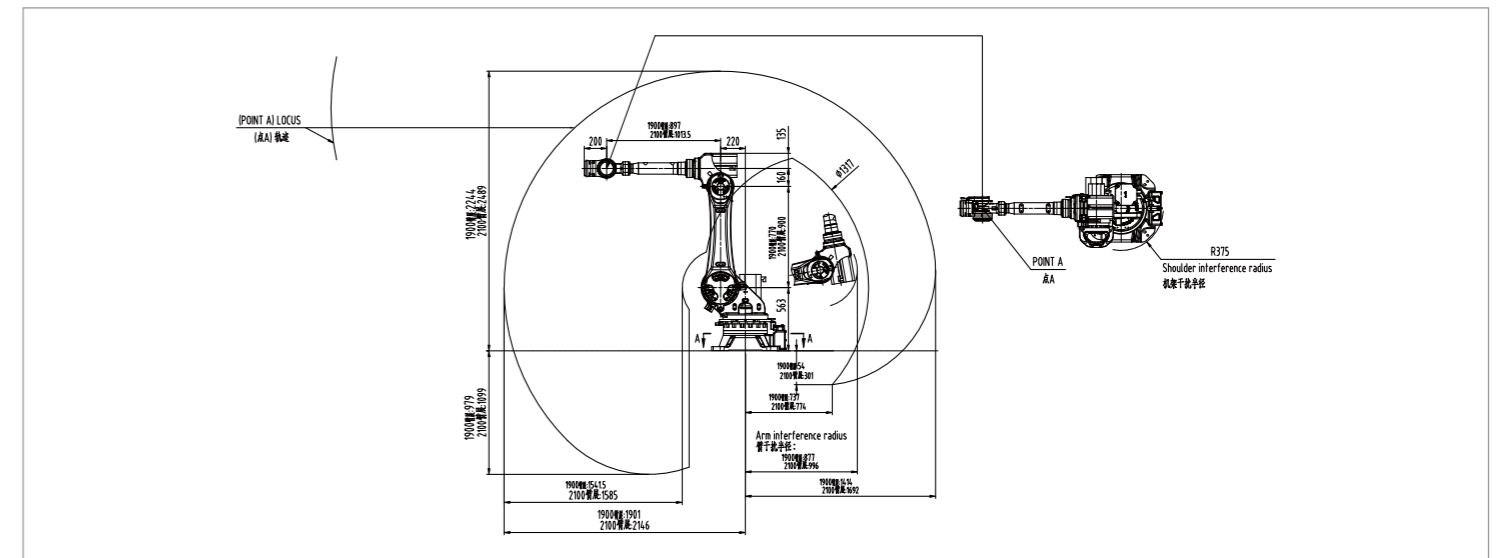

## BASE MOUNTING SIZE

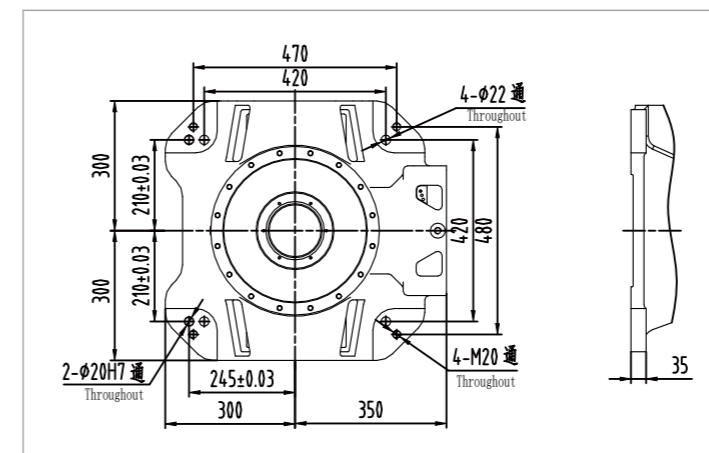

## END FLANGE MOUNTING SIZE

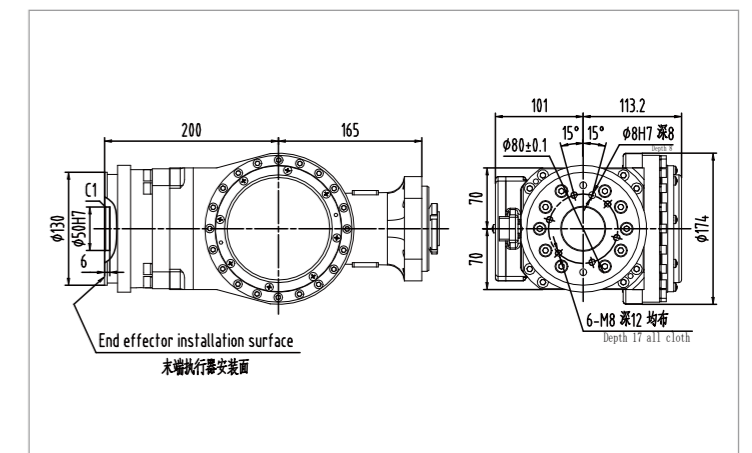

EFORT INTELLIGENT EQUIPMENT CO.,LTD.

PHONE: (00 86) 400-052-8877

ADDRESS: No.96 East WanChun Road, JiuJiang Economic Development Zone, Wuhu, Anhui, China

WWW.EFORT.COM.CN