

Arc Welding Robot

EFORT

ARC12-2000

ARC12-2000 is a medium payloads robot.
Maxium payload 12 kg with maxium reach 2025 mm.

Highlights

Thanks to the large and hollow design, the cable can be routed in a hollow way, effectively improving the service life of the cable, and the posture change in a narrow space is more flexible;
 High-rigid gearbox with strong impact resistance helps customers challenge various application scenarios;
 Thanks to the high stiffness transmission design and advanced trajectory algorithm, the improved robot accuracy performance helps customers to face variety of application scenarios.

Applications

It can be used in Arc welding applications

Industries

Suitable for metal parts, auto parts, steel structure and other industries.



EFORT INTELLIGENT EQUIPMENT CO.,LTD.

PHONE: (00 86) 400-052-8877

ADDRESS: No.96 East Wanchun Road, China(Anhui) Pilot Free Trade Zone Wuhu Area, Wuhu, Anhui Province, China

WWW.EFORT.COM.CN

SPECIFICATIONS

Model	ARC12-2000	
Type	Articulated	
Controlled axes	6 Axes	
Max. payload on wrist	12 kg	
Repeatability	±0.03 mm	
Robot weight	185 kg	
Reach	2025 mm	
Robot IP grade	IP54 / IP67 (Wrist)	
Cabinet IP grade	IP54	
Drive mode	AC servo drive	
Installation	Floor, Upside-down	
Installation enviroment	Ambient temperature	0~45 °C
	Ambient humidity	RH≤80%(No dew nor frost allowed)
	Vibration acceleration	4.9 m/s ² (<0.5 G)

Allowable load moment at wrist	J4	22 N·m
	J5	22 N·m
	J6	9.8 N·m
Allowable load inertia at wrist	J4	0.65 kg·m ²
	J5	0.65 kg·m ²
	J6	0.17 kg·m ²
Maximum speed	J1	220°/sec
	J2	180°/sec
	J3	210°/sec
	J4	420°/sec
	J5	420°/sec
	J6	700°/sec
Motion range	J1	±170°
	J2	+77°/-160°
	J3	+175°/-85°
	J4	±190°
	J5	±190°(The connect outside robot body.) ±140°(The connect inside robot body.)
	J6	±450°(The connect outside robot body.) ±220°(The connect inside robot body.)

OPERATING SPACE

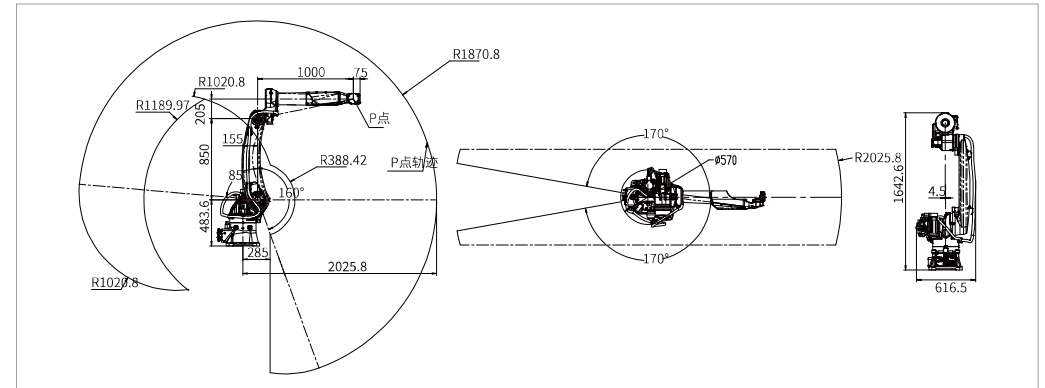

BASE MOUNTING SIZE

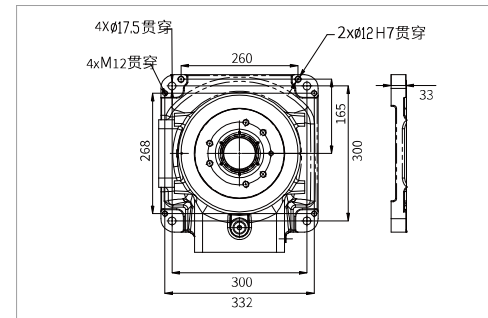

END FLANGE MOUNTING SIZE

